

# THANK YOU FOR HELPING MAKE THE WORLD A MORE SUSTAINABLE PLACE

The Aerobin® is a finely tuned engineered product which, when treated with respect, should give you years of sustainable composting.

## POSITIONING YOUR AEROBIN®

Must be installed on a level, firm and even surface - large pavers or concrete are best, ensure the whole underneath surface is supported as the Aerobin® can weigh up to 200kg. Choose your spot carefully as it is not recommended that you move the Aerobin® once you start using it. If you need to move the Aerobin®, you will need to remove the matter inside first.

## GETTING STARTED

Please see the document that has come with your Aerobin titled 'Aerobin – Composting Tips' – please read and apply the recommendations that have been provided to optimize the performance of your Aerobin. Or visit our website [www.aerobin400.com](http://www.aerobin400.com) and go to Info & Resources and click on Composting Tips.

## WHAT CAN GO IN THE BIN?

Most organic waste, keeping an even mix of Green (wet) and Brown (dry). **See chart below**

## MOISTURE LEVEL

The moisture level of your green materials should be that of a damp sponge. If you wring the material you should get a few drops of moisture. If there are no drops or it appears too dry, add a little water to the materials BEFORE you add to the Aerobin®. If it's dripping wet, add more dry material to even the moisture out. Dropping food scraps into the bin daily helps keep it moist.

## COMPOSTING: HOW IT WORKS

Composting is a natural biological process that releases nutrients from organic matter, and produces fertile humus. The process requires air, moisture, warmth, organic matter and micro-organisms (fungi, bacteria and very small animals, which digest organic matter).

Decomposition starts at quite low temperatures. The insulation in the Aerobin® speeds up this process and the materials breathe through its patented aeration Lung® to provide a more sustainable composting process.

Any soil type will become richer, easier to work and more friable by adding compost, which will also make the soil water retentive, so you won't need to water the garden as much. The nutrients will feed the plants. You will see visible improvement in plant growth and condition in your soil if you regularly apply compost.

## WHEN COMPOST IS IT READY

- > Within three to six months. Allow more time in cold weather or if only adding smaller amounts of material every so often
- > Inspect material via either side access door
- > It is ready when the material is evenly textured, slightly moist and dark
- > Use a small spade or garden trowel to remove mature compost
- > Take care not to damage the central aeration core or lung®

## ORGANIC LIQUID FERTILISER

The base of your Aerobin® contains a chamber to retain excess moisture from composting material. This organic liquid fertiliser is a mixture of moisture and minerals from the decomposing organic materials, and the naturally occurring micro-organisms that help composting occur.

This valuable organic liquid fertiliser can be used on your garden and pot plants to feed the plants. 1 part organic liquid fertiliser to 20 parts water. You will see visible improvement in plant growth and condition in your soil.

Some people prefer to attach a length of 13mm diameter poly pipe to the outlet at the bottom of the unit, with a tap fixed on the end of the pipe to access the organic liquid fertiliser (see "Accessing Compost" in the Frequently Asked Questions section).

## WEEDS AND SEEDS

When used correctly the Aerobin® kills weeds and seeds by heat generated through micro-organic activity in the bin. This activity raises the temperature within the bin. Even in cooler weather the process in the thermally insulated bin generates heat and breaks down compost, which is why you don't need to place the Aerobin® in the sun.

## SAFETY AND HYGIENE\*

Organic household and garden waste material, compost and healthy soil contains living micro-organisms, including bacteria, fungi and protozoa. Depending upon the materials you use, it may also contain chemical, mineral and fertiliser additives.

## RISK

Inhalation of dust and/or liquid mists may irritate, inflame or sensitise the nose, throat and lungs resulting in illnesses ranging from hayfever or asthma to pneumonia (e.g. Legionnaire's disease) or pneumonia-like illnesses. Direct contact with this material or its dust and/or liquid mists (bio-aerosols) may cause skin irritation (dermatitis), and skin or eye infection or irritation.

People particularly at risk are those suffering from asthma or allergies, and those whose immune defence systems are compromised.

## SAFETY

### AS WITH ALL COMPOSTS AND MULCHES:

- > Avoid contact with eyes and skin.
- > Avoid breathing or ingesting dust and/or liquid mists (bioaerosols).
- > Wear suitable protective clothing and standard duty gloves.
- > If exposed to dust and/or liquid mists, also wear dust resistant eye protection and particulate respirator.
- > Wash thoroughly immediately after handling decomposing materials. Wash work clothes regularly.

## FIRST AID

Irrigate eyes with plenty of water for 10 minutes. Wash skin with soap and water. Seek medical attention for any persistent skin, eye or - respiratory symptoms.

# QUESTIONS AND ANSWERS

## WHAT CAN GO IN

### CAN I PUT ANIMAL FAECES IN IT?

In most jurisdictions it is illegal to put carnivore (meat eating animal) faeces in the Aerobin®. However, herbivore (grass/plant eating animal) manure, e.g. horse, cattle, goat, sheep, poultry manure can be included. All animal faeces may carry pathogens, as may all finished compost, therefore handle strictly according to safety and hygiene guidelines.

### CAN I PUT ASHES IN IT?

It is not recommended. Hot Ash will damage the plastic and void the warranty. Too much ash will slow down the composting process.

### DOES IT REALLY BREAK DOWN NEWSPAPER?

Yes, the Aerobin® breaks down all organic waste including newspaper and office paper, which must be scrunched up into balls before loading into the Aerobin. If adding a lot of newspaper without wet materials, moisten first. Cardboard strips will also breakdown and will help to provide structure (improving air flow) within the biomass you are loading into the Aerobin.

### CAN I PUT DAIRY PRODUCTS IN IT?

Dairy products can give off an unpleasant odour when decomposing, and should only be used if the Aerobin® is in a location where the pungent smell will not offend anyone.

## ACCESSING COMPOST

### HOW DO I GET COMPOST OUT?

Through the two side access panels in the bottom chamber. Using the handle, lift the panel vertically to unlock, then pull toward you. When replacing it, ensure side access panel locks back in place to minimise odours and keep out pets and pests. Listen for the click when it locks in.

### HOW MUCH LIQUID FERTILISER CAN THE TANK HOLD?

5 litres.

### HOW DO I GET THE LIQUID FERTILISER OUT?

Drain the liquid fertiliser from the outlet at the base of the Aerobin® into a low-sided container. The outlet pipe, which turns, has an integrated valve. When the outlet pipes is at the bottom position the tap is "open", allowing the liquid fertiliser to flow and when the outlet pipe is at the top position the tap is "closed" (see diagram on page 1). It is recommended that you turn the valve several times to loosen the barrel before putting material into the Aerobin®.

Some people prefer to attach a 13mm diameter poly pipe, with a tap fixed on the end of the pipe. This way the outlet can be left on and the tap used to stop and start the flow. If the outlet becomes blocked simply use a skewer or piece of wire to remove blockage from the valve, whilst in the open position.

Please carefully follow the safety and hygiene guidelines in this leaflet when handling the fertiliser.

### DOES THE LIQUID FERTILISER TANK GET SLUDGE IN IT?

Some sludge may build up over time, the residue of small particles of organic material. It is recommended that you completely empty the liquid fertiliser from the tank once or twice a year, attach a hose to the outlet and back flush the contents for 3 minutes.

## HOW THE AEROBIN® WORKS

### DOES THE AERATION CORE OR LUNG® TURN?

No. The Aerobin® has a static Aeration Core or Lung® allowing passive ventilation throughout the whole composting mass. No turning or churning is required.

### DO I NEED TO KEEP THE AEROBIN® IN THE SUN?

No. The heat inside the Aerobin® comes from the micro-organisms breaking down the organics, not from the sun.

### IS IT GUARANTEED TO MAKE GOOD COMPOST?

University tests have proved compost from the Aerobin® is superior to compost from other leading international compost units, when contents are mixed evenly and at the right moisture level. The tests achieved Rottegrad 4 standard (one step down from the top level) after just 13 weeks. The test indicated Rottegrad 5 standard would be achieved given a little more time

### CAN I KEEP IT INSIDE?

Plenty of airflow is required, and if kept indoors a composting odour may be evident, so it should be kept outdoors.

### Can I get spare parts for the Aerobin®?

The Aerobin® is exceptionally resilient and should not break, however, replacement parts are available at a charge. You may freecall the hotline on 1800 615 445 or email [info@aerobin.com.au](mailto:info@aerobin.com.au) to order spare parts.

## WORMS

### HOW DO WORMS GET IN?

Aerobin® doesn't actually need worms to operate, however compost worms greatly enhance the composting process and may get in through small holes in the bottom of the Aerobin®.

### WILL IT KILL WORMS?

Worms may die if placed in the top of the unit due to the high temperatures generated by the composting procedure. They should survive and thrive at the bottom of the unit.

## GUARANTEE AGAINST DEFECTS

Our Aerobin comes with guarantees that cannot be excluded under Australian Consumer Law. You are entitled to a replacement or refund for a major failure and for compensation of any other reasonably foreseeable loss or damage. You are also entitled to have the goods repaired or replaced if the goods fail to be of acceptable quality and the failure does not amount to a major failure.

The Aerobin is guaranteed for 3 years against manufacturing or material defects.

Please contact and direct your claims to the offices of Global Environment Management Australia Pty Ltd (see details below)

You will be required to provide proof of purchase when making a claim. GEM Australia Pty Ltd will have the right to inspect the Aerobin to assess the claim – either physically or via photographic evidence you will provide or by any other agreed means.

The provisions of GEM-A Pty Ltd 'Guarantee Against Defects' are in addition to other rights and remedies you have under law in relation to the goods or services to which the guarantee relates.

## ADDITIONAL HELP

**E-mail:** [info@aerobin.com.au](mailto:info@aerobin.com.au)

**Phone:** Aerobin® Hotline 1800 615 445 Freecall 09:00 - 17:00 AEST, Monday - Friday except Victorian public holidays.

**Website:** [www.aerobin.com.au](http://www.aerobin.com.au) or [www.aerobin400.com](http://www.aerobin400.com)

### GREEN (WET) MATERIALS

- > Food scraps
- > Citrus and onions (Cut up)
- > Vegetable peelings
- > Lawn clippings\* and weeds
- > Green garden cuttings
- > Coffee grounds
- > Tea-leaves and tea bags

### BROWN (DRY) MATERIALS

- > Leaves and small twigs
- > Crumpled into balls - either newspaper or office paper
- > Roots or branches, finely chipped or mulched
- > Long yellow grass
- > Pea Straw

\* (note: "Sir Walter Buffalo" grass is very moist, so mix it with more dry materials)

### DO NOT USE...

- > Oils
- > Meat
- > Fish
- > Wood
- > Glossy magazines
- > Ash
- > Faeces from meat eating animals
- > Dairy



Global Environment Management

Global Environment Management Australia Pty Ltd  
Unit 4, 18-22 Lexia Place, Mulgrave  
Victoria 3170, Australia

FREECALL 1800 615 445 within Australia  
F +61 3 8561 7999  
W [www.aerobin400.com](http://www.aerobin400.com)  
I [info@aerobin.com.au](mailto:info@aerobin.com.au)

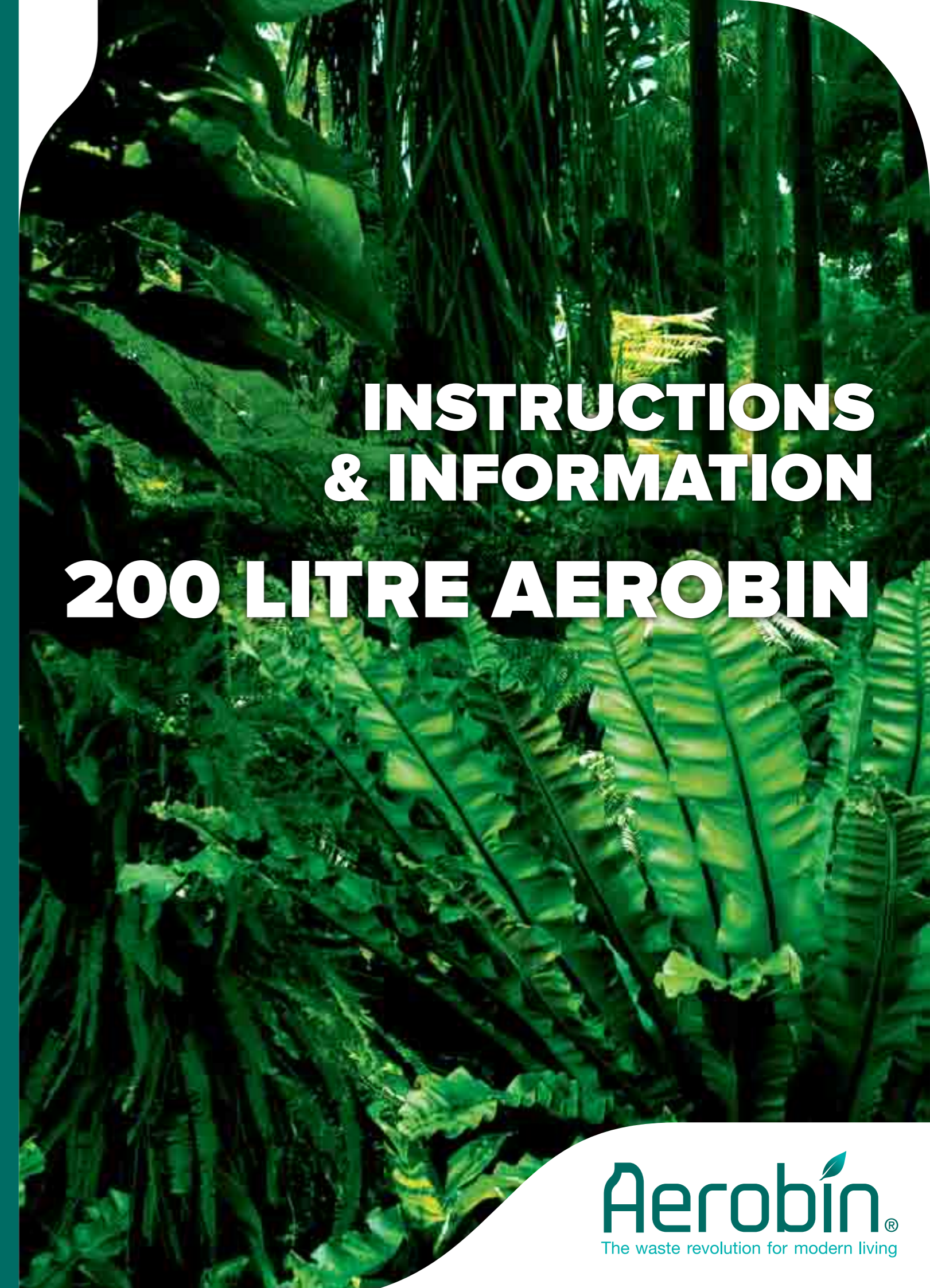

# INSTRUCTIONS & INFORMATION

# 200 LITRE AEROBIN

**Aerobin®**  
The waste revolution for modern living

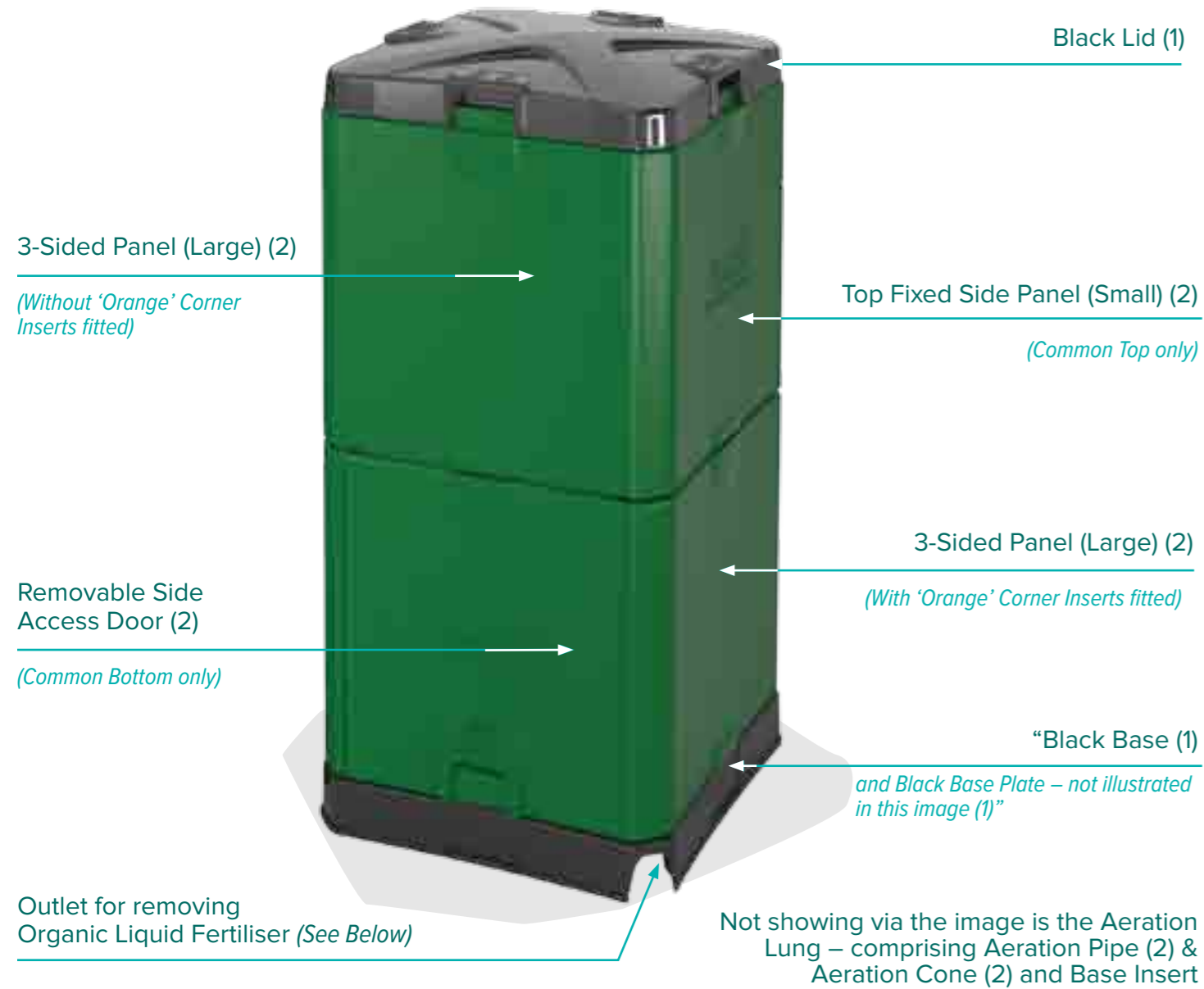

## ASSEMBLY INSTRUCTIONS 200 LITRE AEROBIN

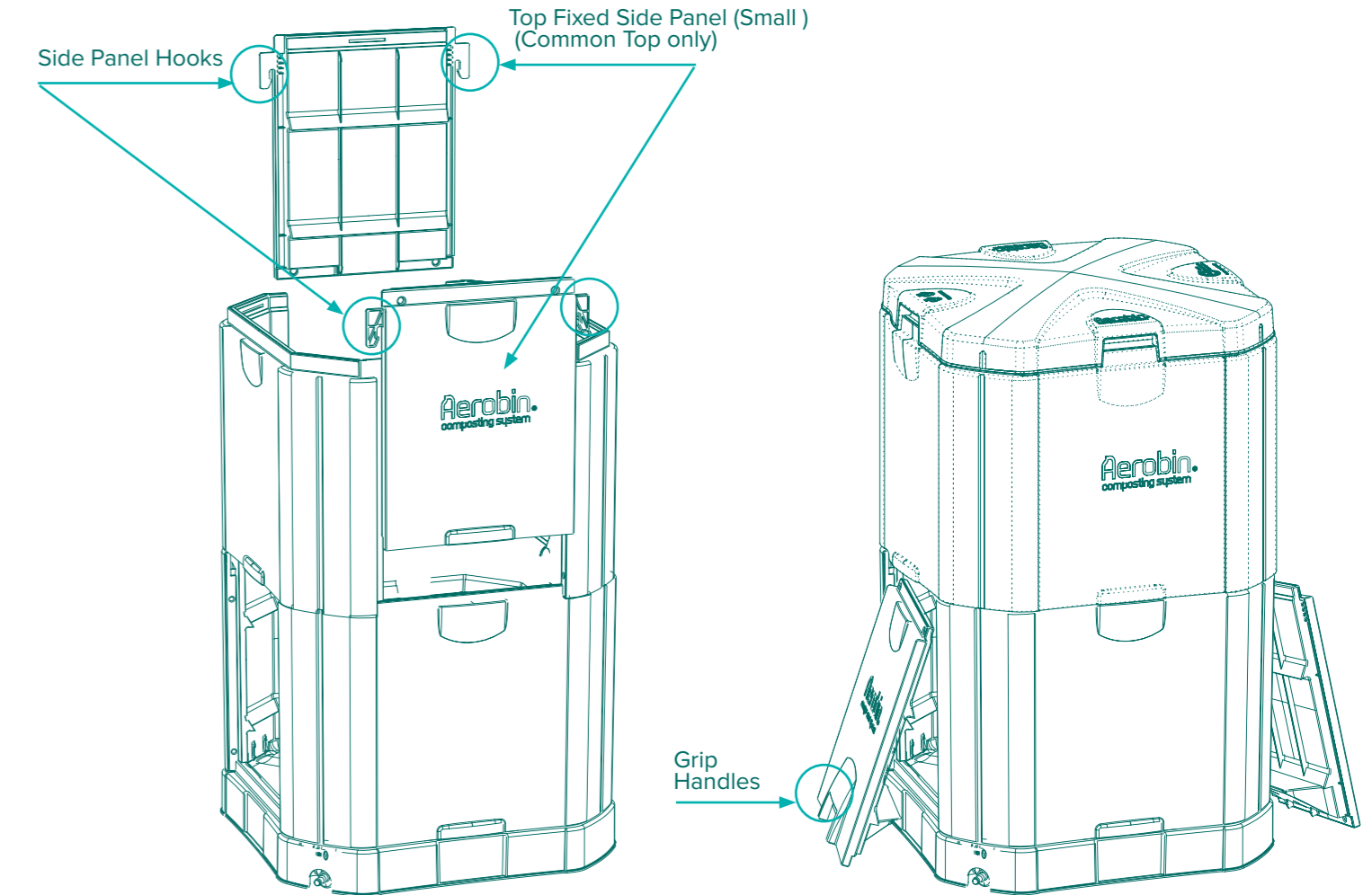
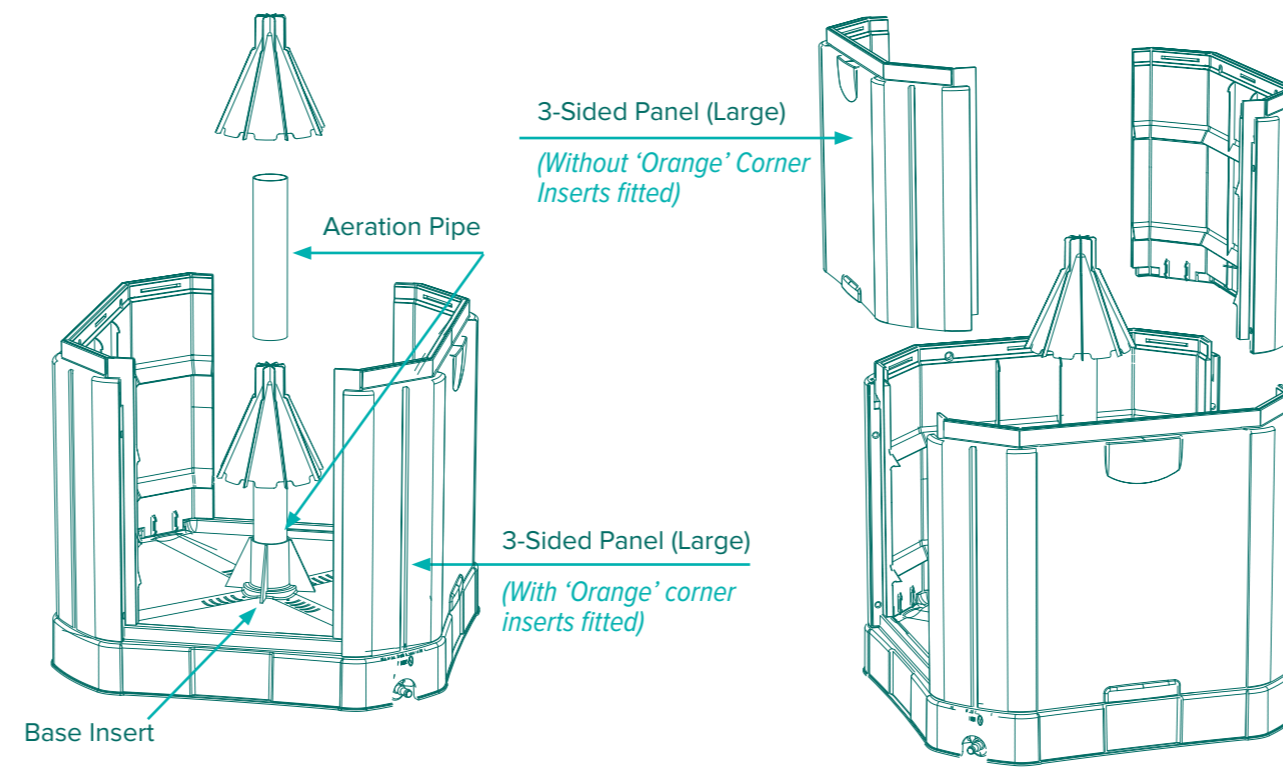

### STEP 1.

- > Remove all components from carton and check off against assembled Aerobin image and component titles – see opposite page
- > Fit Black Base Insert into Black Base – ensure that the Insert sit flush around its parameter into the Base recess
- > Fit lower level 3-Sided Panels to Base – these have the 'Orange' corner inserts – ensure engaged properly to Base (pull upward)

### STEP 2.

- > Insert Aeration Pipe into Base – tap down until Pipe bottoms in Base
- > Press lower Aeration Cone onto the Aeration Pipe – tap down until the Cone bottoms on the Pipe
- > Press second Aeration Pipe onto the top of the lower Aeration Cone – tap down until the Pipe bottoms on the Cone
- > Press the second Aeration Cone onto the top of the second Aeration Pipe – repeat earlier step

### STEP 3.

- > Place one of the remaining 3-Sided Panels (Large) across the corners of the lower level 3-Sided Panels – push down to lock – ensure engaged properly (pull upward) – repeat steps with last remaining 3-Sided Panel
- > The opening below the top level 3-Sided Panel is where the 'Removable Side Access Door' will be fitted

### STEP 4.

- > Slide the Top Fixed Side Panels into place
- > Lock them into the 3-Sided Panel (Large) by the hooks provided
- > Ensure all Panels are flush with each other

### STEP 5.

- > Place the Lid on the top of the Aerobin®
- > Slide the two Removeable Side Access Doors into position by sliding the top in first, position the door and slide back down (5mm) until a click is heard or felt, to lock
- > If the door can be pulled straight out without lifting first, **the door is NOT** locked into position

**Congratulations you are now ready to use your Aerobin® ! - but before you start ensure that the Aerobin is positioned on a very firm foundation**

WHEN FIRST INSTALLING YOUR AEROBIN POSITION IT ON A VERY FIRM AND LEVEL FOUNDATION OR SURFACE – NOT DIRECTLY ONTO GARDEN SOIL OR LAWN



## PROBLEM SOLVING

PROBLEM	SOLUTION
<b>WHEN TOO WET:</b> 1. Compost not heating up. 2. Not decomposing. 3. Bad smells.	Take out the material from the Aerobin® and put it back in, layering with brown (dry) material. Newspaper (scrunched up or shredded) and pea straw are counted as brown and will help. If large leaves or green garden matter is not decomposing, shred into smaller pieces.
<b>WHEN TOO DRY:</b> Not decomposing	Take out the material from the Aerobin® and start the process again, being careful to layer even amounts of brown (dry) and green (wet) materials. If the compost is too dry, it may become water repellent and very hard to re-wet. Avoid putting dry materials in the bin unless moistened or mixed with high moisture-containing materials such as kitchen scraps.
<b>INSECTS:</b> Attracts insects, millipedes, slugs	It is normal to have small flies, insects and other invertebrates in the Aerobin® ; they are part of the decomposing process. If small flies are annoying, cover with shredded paper, grass clippings or use pyrethrum spray.